



***Process calibrator  
Multimeter***

***ZUTEMER 77***

***User Manual***

**[www.zutemer.cz](http://www.zutemer.cz)**

# WARRANTY

Our company warrants to the original purchaser that each product it manufactures will be free from defects in material and workmanship under normal use and service for a period of one year from date of purchase. Our company's warranty does not apply to fuses, test leads or any product which, in our company's opinion, has been misused, altered, or damaged by accident or abnormal conditions of operation or handling.

To obtain warranty service, contact your nearest Service Center (or send the product, with a description of the difficulty, and postage prepaid, to the nearest Service Center). Our company assumes no risk for the damage in transit. Our company will, at its option, repair or replace the defective product free of charge or refund your purchase price. However, if our company determines that the failure was caused by misuse, alterations, accident or abnormal condition of operation or handling, you will be billed for the repair and the repaired product will be returned to you transportation prepaid.

## SHIPPING TO MANUFACTURER FOR REPAIR OR ADJUSTMENT

All shipment of our company's instruments should be made via United Parcel Service or "Best Way" prepaid. The instrument should be shipped in the original carton; or if it is not available, use any suitable container that is rigid and of adequate size. If a substitute container is used, the instrument should be wrapped in paper and surrounded with at least

four inches of excelsior or similar shock-absorbing material.

## **CLAIM FOR DAMAGE IN SHIPMENT TO ORIGINAL PURCHASER**

The instrument should be thoroughly inspected immediately upon original delivery to purchaser. All material in the container should be checked against the enclosed packing list. The manufacturer will not be responsible for shortages against the packing sheet unless notified immediately.

If the instrument is damaged in any way, a claim should be filed with the carrier immediately. (To obtain a quotation to repair shipment damage, contact the nearest Service Center.) Final claim and negotiations with the carrier must be completed by the customer.

# INDEX

	P a g e
1. Safety Information.....	1
2. Instrument Panel Layout and Functions.....	2
3. Instrument Maintenance.....	3
4. Power-on/off of Instrument.....	4
5. Output from Instrument.....	5
6. Instrument Measurement.....	7
7. Setting Function.....	10
8. Performance Index.....	11
9. Calibration.....	12
10. Notice of the Manual.....	15

## **Section One Safety Information**

To ensure the safety operation, the following signs are used only as specified in this operation instruction:

 **Warning** A warning shows that if the operation does not comply with the following correct instruction it is possible to bring hazards to the user or cause damage to the instrument in use. The warning also points out how to avoid the accidents.

 **Caution** A caution shows that if the operation does not comply with the following correct instruction, it is possible to cause damage to the instrument in use. The caution also points out how to avoid mal-operation.

 **Note** A note serves as a sign to remind the user that is must understand the correct operation of the instrument and its characteristics.

To prevent the user and the Instrument from any electric shock and other hazards, it is necessary to observe the following regulation:

 **Warning**

- It is not allowed to operate the Instrument at the working field where there exists flammable gas or explosive gas or vapor. It is very dangerous to operate the instrument in such a surrounding.

- Never apply more than 30V between any two terminals, or between any terminal and earth ground.

 **Caution**

- No one is allowed to remove the split case of the Instrument except professionals.

- Periodically wipe the case with a damp cloth and detergent; do not use any corrosive solvents.

 **Note**

- To keep the Instrument in a designed accuracy, it needs warming up 5 minutes before it is put into operation.

- If any user requires a higher accuracy of the calibrator, he or she is requested to make contact with the manufacturer or our product distributors.

## Section Two Instrument Panel Layout and Functions

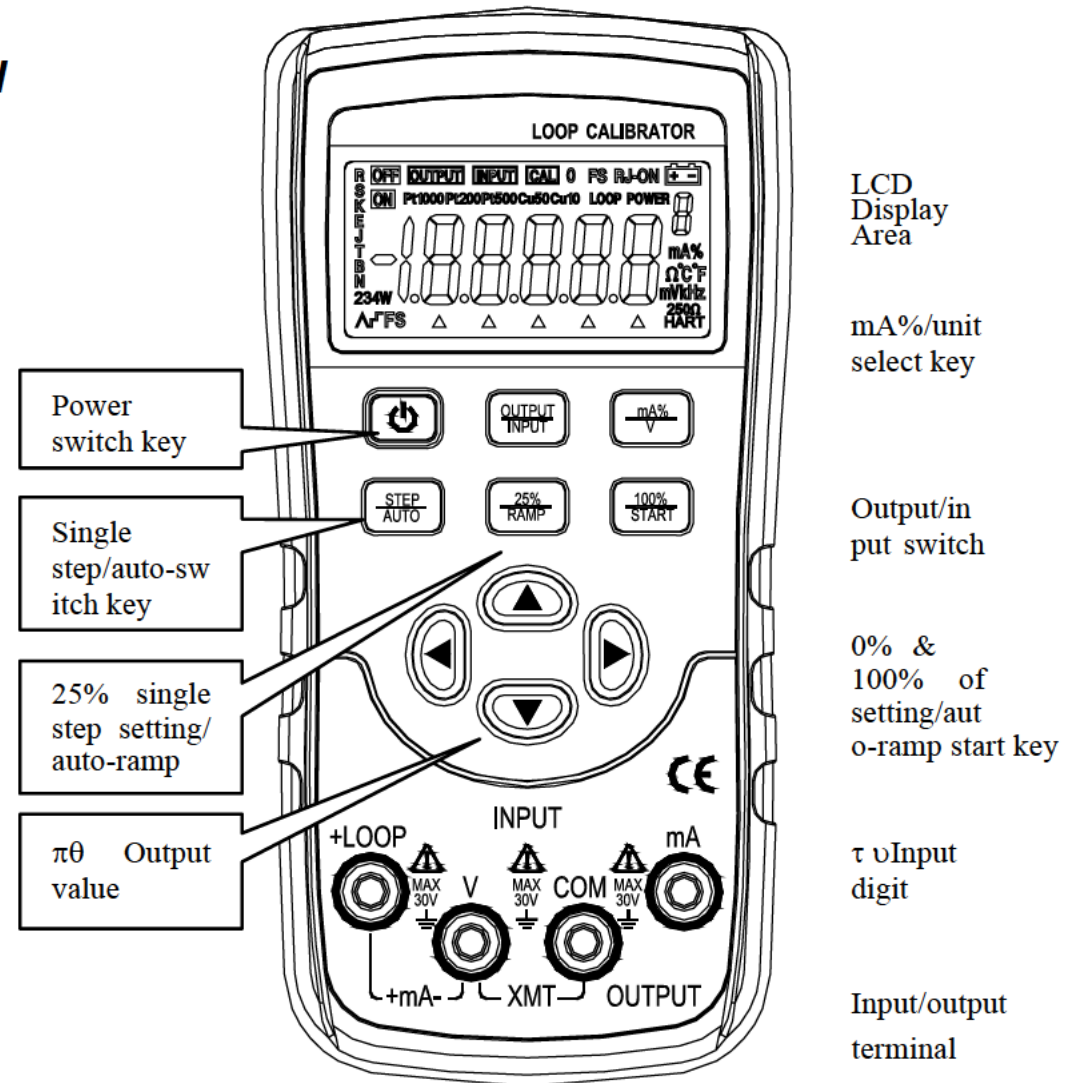

**Illustration of LCD Display Area**

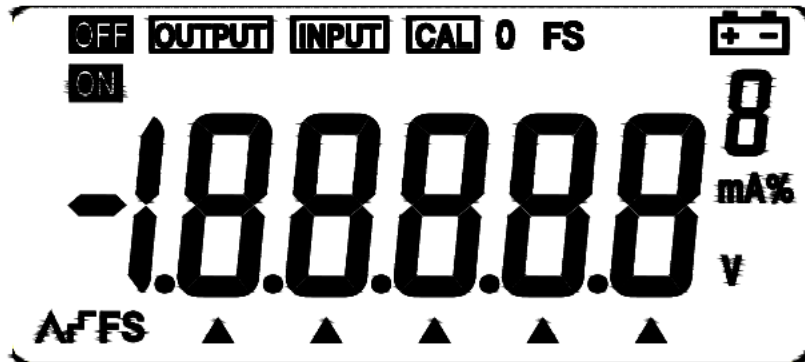

**OUTPUT** : Press the key (**OUTPUT / IN / SW**) when the symbol **OUTPUT** appears. It denotes that the Instrument is in a state of output.

**INPUT** : Press the key (**OUTPUT / IN / SW**) when the symbol **INPUT** appears. It denotes that the Instrument is in a state of input.

**CAL** : When the symbol **CAL** appears, it denotes that the Instrument is in a state of calibration.

**0 FS** : When the symbol 'O' or 'FS' appears during the calibration, it denotes that the zero point or the full scale point is being calibrated.

 : When this symbol appears, it denotes that the battery is nearly used up and needs replacing.

$\pi$  : When this symbol appears, it denotes that the output digits need setting.

V、mA、% : These symbols denote the units of both present input and output values.

**ON**、**OFF** : These symbols denote the turn-on or turn-off of any input / output signals.

 : These symbols denote the high and low-speed auto-ramp, auto-step ramp.

### **Section Three Instrument Maintenance**

This section provides some basic maintenance procedures. Repair, calibration, and servicing not covered in this manual must be performed by qualified personnel. For maintenance procedures not described in this manual, contact a Service Center.

#### **General Maintenance**

Periodically wipe the case with a damp cloth and detergent; do not use abrasives or solvents.

- Take out the batteries if the Instrument will not be used for a long time.
- Dirt or moisture in the terminals can affect readings.

Clean the terminals as follows:

- 1) Turn the Instrument off and remove all test leads.
- 2) Shake out any dirt that may be in terminals.
- 3) Soak a new swab with alcohol. Clean each terminal with the swab.

#### **Replacing the Batteries**

This Instrument is powered by two AA batteries (IEC LR6).

**⚠ Warning**

To avoid electrical shock or personal injury:

- Remove Test Leads from the Instrument before opening the battery door.
- Close and latch the Battery Cover before using the meter.

**⚠ Note**

- The new and old Batteries cannot be mixed.
- Make sure the battery's poles are in accordance with the marks illustrated in battery pool when replacing them.
- Take out the batteries if the meter will not be used for a long time.
- Dispose the old batteries in accordance with the local law.

Replace the batteries as follows.( See Figure 3-1):

- 1) Turn off the Instrument and remove all Test Leads from the Terminals;
- 2) Take off the protector of the Instrument; remove the battery cover by using a standard-blade screwdriver to turn the battery door fasteners, and then take of the battery case;
- 3) Replace with two new batteries;
- 4) Reinstall the battery case and tighten screws.

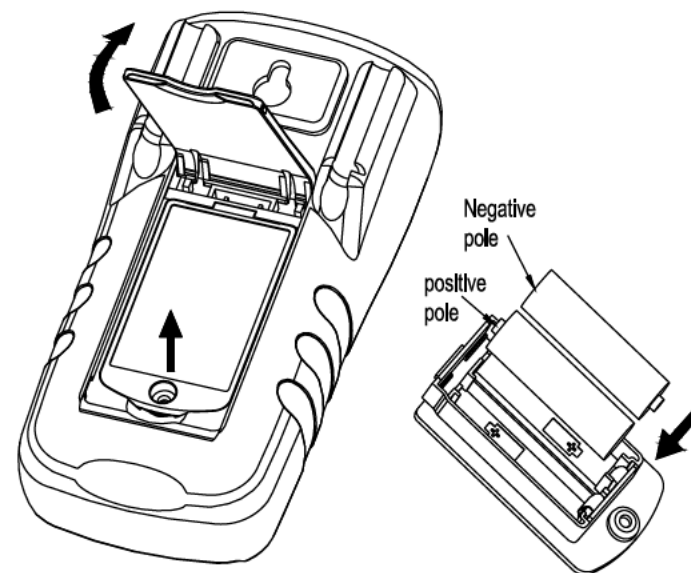

Figure 3-1 Replacing batteries

**Replacing Fuse**

**⚠ Warning**

To avoid personnel injury or damage to the meter, use only the specified fuse. The specification is 63mA 250V fast-melt.

Replace the fuse as follows (Refer to Figure 3-2 if necessary):

- 1) Remove the test leads from the meter and turn the meter OFF;
- 2) Take off the protector of the meter, remove the four screws by using a standard-blade screwdriver, and then take off the cover;
- 3) Replace the blown fuse(s);



- 4) Reinstall the cover;
- 5) Reinstall the meter's protector.

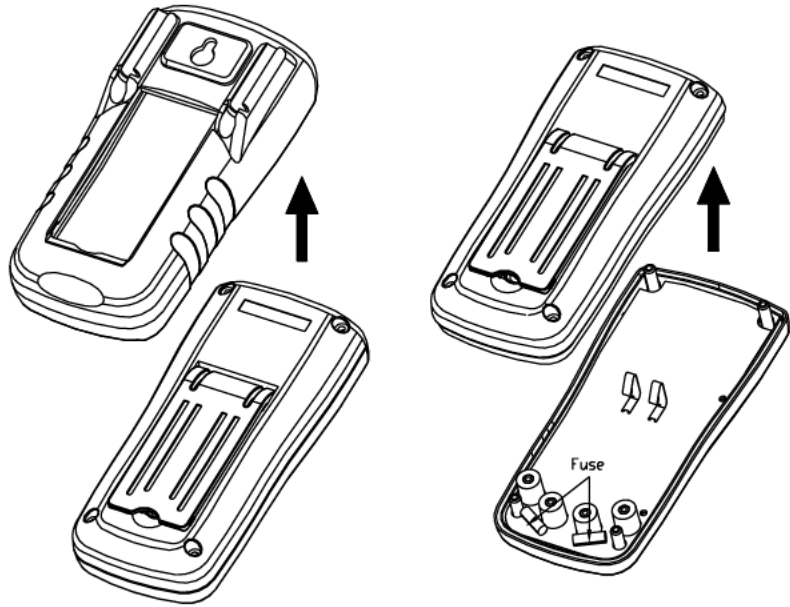

Figure 3-2 Replacing fuses

## **Section Four Power-on/off of Instrument**

### **Power on/off**

Press the power key to turn on the power supply of the Instrument. Then repress it to hold it in one second and the power will be off.

When the power is turned on, the Instrument starts to make self-diagnosis internally and the full screen is in display. After this, appropriate operation should be

carried out.

### **⚠ Note**

To ensure correct operation of the Instrument, it is recommended to turn off the power pausing 5 seconds and then restart the Instrument.

### **Automatic Power-off**

The factory default setting is that the Instrument will cut off the power automatically if no operation applied to the Instrument within 15 minutes.

Users can decide whether they want to use this function or not.(See Section 7 for reference)

## **Section Five Output from Instrument**

The Instrument produces the DC current from its appropriate output terminal (OUTPUT) set by the user or simulating a transmitter.

### **⚠ Caution**

Do not apply voltage to the output terminal during the operation. If any improper voltage is applied to the output terminal, it will cause damage to the internal circuit.

### **Output Operation Procedure**

Function Operation	% Operation	Display	Setting Range
DCI 20mA	20 mA 2 %	00.000 mA  -025.00 mA %	00.000~22.000 mA  -025.00~112.50 mA %

### Current Output

- 1) Insert one end of the test leads to the + mA – output jack ( OUTPUT ) of the Instrument and connect the other end with the input of the user's Instrument as shown in Figure 5-1:

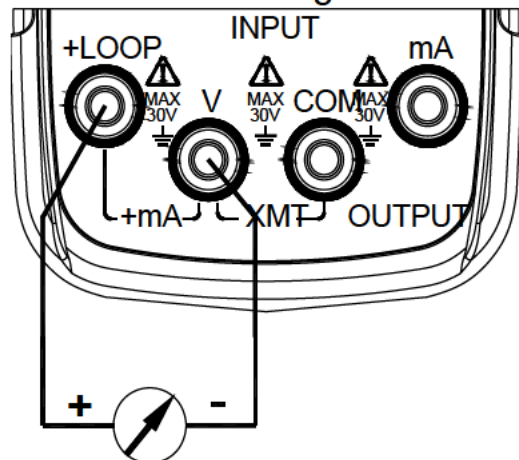

Figure 5-1

- 2) Press the key ( OUTPUT/IN ), and the OUTPUT appears in the display. It denotes that the

- Instrument is in an output state;
- 3) Press the key ( mA%/V ), to select the output to be set in 'mA' or %, and then the unit mA or mA% appears, in which 0% denotes 4mA; 100% denotes 20mA;
- 4) Press the key ( τ ) / ( υ ) to select the set digits of the output;
- 5) Press the key ( π ) / ( θ ) to change the value of the set digits. The value can do carry or number decrement automatically. Hold the pressed key in one second and the numerical value will keep varying.

### 25% Step Current Output

- 1) Connect to the Instrument as shown in Figure 5-1;
- 2) When the key ( OUTPUT/IN ) is pressed, the OUTPUT appears in the LCD, it denotes the Instrument is in an output state;
- 3) Press the key ( 25%/RAMP ) and the symbols 'F' and 'π' will appear;
- 4) Press the key ( mA%/ V ) to select the output to be set in mA or %, and then the unit 'mA' or 'mA %' appears;
- 5) Press the key ( π ) / ( θ ) to change the output in a value of 25%, in which 0% denotes 4mA and 100% denotes 20mA;

- 6) Repress the key (25%/RAMP) so as to exit the step current output.

### **Current Output Set for Zero Point & Full Scale**

- 1) Connect to the Instrument as shown in Figure 5-1;
- 2) When the (OUTPUT/IN) key is pressed, the OUTPUT appears in the LCD, it denotes the Instrument is in an output state;
- 3) Press the key (100%/START) and the symbols 'F', 'π', '0', 'FS' will appear in the display;
- 4) Press the key (π) to be set to 100% and the current output will be 20mA. Press the key (θ) to be set to 0% and the current output will be 4mA;
- 5) Repress the key (100%/START) so as to exit the step current output.

### **Auto-ramp Output**

- 1) Connect as shown in Figure 5-1;
- 2) When the key (OUTPUT/IN) is pressed, the **OUTPUT** appears in the LCD, it denotes the Instrument is in an output state;
- 3) When the key (STEP/AUTO) is pressed, the symbols 'OUTPUT', 'OFF', '⌒' along with '4mA' appear in the LCD. If so, it denotes that the Instrument is getting into the mode of RAMP;
- 4) Repress the key (25%/RAMP) again so as to

change the type of the output ramp, which finds itself in the lower left of the LCD. The type appears with 'A S', 'F', 'Λ F', in proper order. These symbols denote a low speed ramp and a high speed ramp respectively. The former is set to a cycle up to 60S and the latter is up to 30S, while the auto-stair step ramp pauses 5 seconds at each step;

- 5) Press the key (100%/START) to start the output of the set waveform when the symbol 'ON' appears. Now repress the key (100%/START) again and the output will pause on a current value and the symbol 'OFF' will appear. Then press the same key again and the output will continue to do the set steps from the pause value. When the symbol 'OFF' appears, press any one of the keys (τ), (υ), (π), (θ) so as to bring the output back to the 0%. Then the value of 4mA appears in the display.

### **Simulating Transmitter Output (XMT)**

- 1) Insert one end of the test lead to the 'XMT' output jack of the Instrument and connect the other end with the input terminal of the user's device as shown in the Figure 5-2:

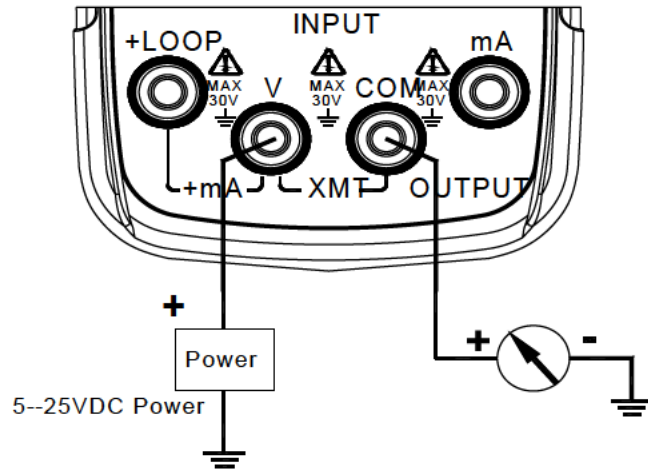

Figure 5-2

2) The key-operation is the same as that of the current output.

**⚠ Note**

- Range of power supply: 5 to 25VDC.
- Usage: during the operation of the current output, use the external 24VDC power supply in a mode of connecting a transmitter, thus being able to prolong the working life of the battery.

**Section Six Instrument Measurement**

**⚠ Warning**

During the operation, never apply more than 30V between any two terminals, or between any terminal and

earth ground. Any voltage more than 30V will not only do damage to the Instrument, but also lead to possible personal injury.

**⚠ Caution**

- During the operation, do not apply a voltage or current exceeding the measuring range to the input terminal, which will cause possible damage to the Instrument.
- When connecting to the Instrument, the power supply of the device under test should be cut off. Otherwise, any connection with a device without cutting off its power supply will cause possible damage to the Instrument.

**Input Operation Procedure**

Function Operation	%Operation	Display	Measurement Range
DCI	20 mA	00.000 mA	-1.000~22.000 mA
20 mA	2		
2 2	%	-25.00 mA %	-31.25~112.50 mA %
DCV			
28 V		0.000 V	-0.2000~28.000 V

### Measuring DC Current

- 1) Insert one end of the test lead into the mA jack of the Instrument (INPUT) terminal and connect the other end to the output of the user's device as shown in Figure 5-3:

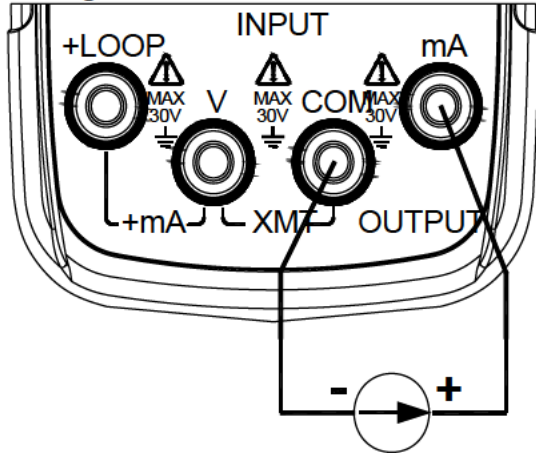

Figure 5-3

- 2) Press the key (OUTPUT / IN) , the LCD displays 'INPUT', and it denotes that the Instrument is in an input state.
- 3) Press the key (mA%/V) to select the input to be set in 'mA' or 'mA %', and the LCD displays unit 'mA' or 'mA %', in which the value of 0 % denotes 4mA and the value of 100% denotes 20mA.
- 4) The Instrument starts measurement, and the LCD displays 'ON', and the measured result simultaneously.

- 5) The refreshing rate of measurement result is twice every second. And the LCD displays 'OL' if the measured value exceeds the measuring range.

### Measuring DC Voltage

- 1) Insert one end of the test lead into the V jack of the Instrument (INPUT) terminal and connect the other end to the output of the user's device as shown in Figure 5-4:
- 2) Press the key (OUTPUT / IN) , the LCD displays 'INPUT', and it denotes that the Instrument is in an input state.
- 3) Press the key (mA%/V) to select V function, and the LCD displays unit 'V'.
- 4) The Instrument starts measurement, and the LCD displays 'ON', and the measured result simultaneously.
- 5) The refreshing rate of measurement result is twice every second. And the LCD displays 'OL' if the measured value exceeds the measuring range.

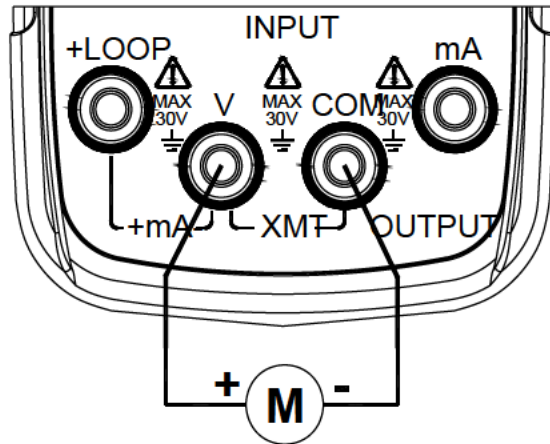
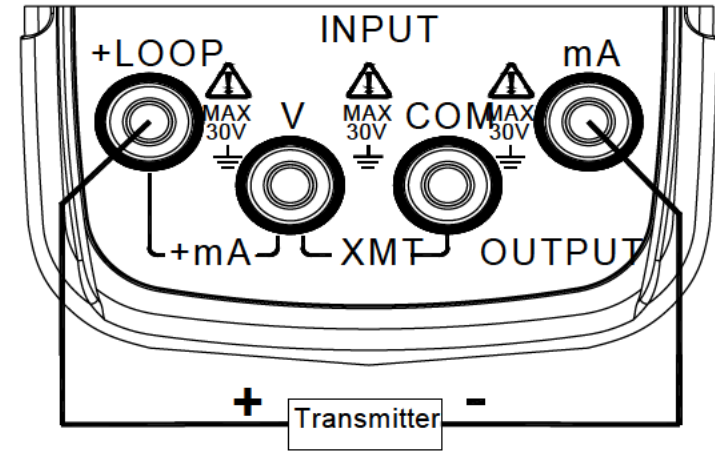

Figure 5-4



### **Providing 24V Power Supply for Measuring Loop Current**

Insert the test lead into the +LOOP and mA input jacks of the input terminal (INPUT) of the Instrument as shown in Figure 5-5:

The key operation is the same as that of measuring the DC current.

### **Section Seven Setting Function**

Fulfilling of the following operation will change the auto-power-off function of the Instrument:

In power-off state, press the keys (mA%/V) and (power) simultaneously to power on, and release the (mA%/V) key only after the LCD displays all the contents. The Instrument enters into the calibration mode, and the symbols 'AP -XX' appear in the LCD;

Press the key ( $\pi$ ) / ( $\theta$ ), and when the LCD displays 'AP- OF', the Instrument removes auto-power-off function; And when the LCD displays 'AP- ON', the Instrument recovers the auto-power-off function.

Press the key (100%/START) to store the selection;

Cut off the power again to exit from the maintenance function.

### **Section Eight Performance Index**

Output Performance Index (applicable to temperature range from 18°C to 28°C, within one year after calibration)

<b>Output</b>	<b>Range</b>	<b>Output Range</b>	<b>Resolution</b>	<b>Accuracy</b>	<b>Remark</b>
DCA	20mA	0.000~22.000mA	0.001mA	±0.05% set value ±4uA	Max. load 1KΩat 20mA.
Simu-transmitter(absorption current)	-20mA	0.000~-22.000mA	0.001mA	±0.05% set value ±4uA	Max. load 1KΩat 20mA. Note: power supply range: 5~25VDC
Loop Power Supply	24V			±10%	Max. output current up to 25mA.

Input Performance Index(applicable to temperature range from 18°C to 28°C, within one year after calibration)

Input	Range	Output Range	Resolution	Accuracy	Remark
Voltage	28V	-0.200~28.000V	1mV	±0.02% reading±2mV	Input resistance about 1MΩ
Current	20mA	-1.000~22.000mA	0.001mA	±0.02% reading±4uA	resistance about 20Ω
Loop Current	20mA	0.000~22.000mA	0.001mA	±0.02% reading±4uA	providing 24V loop power

### **General Specifications**

Power supply	:	2 1.5V alkaline batteries(LR6)
Battery life	:	about 400mA /3V under the condition of 10mA with 1kΩ load
Max. permitted voltage	:	30V(between any two terminals or between any terminal and earth ground)
Operating temperature	:	0°C to 50°C
Operating relative humidity	:	≤80% RH
Storage temperature	:	≤-10°C to 50°C
Relative humidity for storage	:	≤90% RH
Temperature co-efficiency	:	0.1× (designated accuracy) %/°C (5°C~18°C、28°C~40°C)
Size	:	180 (L) ×90 (W) ×47 (D) mm (with holster)
Weight	:	500g(with holster)
Accessories	:	operation instruction, a set of CF-36 industrial test lead(with alligator clips attached to probes)
Safety	:	certified as compliant to IEC1010 provisions(Safety standard issued by International Electrotechnical Commission)

### **Section Nine Calibration**

 **Note**



- Calibration: In order to keep the designed accuracy of this Instrument, it is recommendable to calibrate your calibrator once a year. The following example shows the use of recommended standard equipment to perform the calibration.

⚠ Caution

- Usage: Never apply more than the max. permitted voltage to the input of the calibrator, otherwise the overvoltage will lead to possible damage to the input section.
- Usage: during the operation, avoid short circuit and never apply more than the max. permitted voltage to the output of the Instrument or to a co-working standard device, otherwise any mal-operation will cause possible damage to their internal circuits.

**Selecting Standard Equipment**

Table 10-1

Calibration Item		Standard Equipment	Output Range	Accuracy	Recommended
Output	DCA 20mA	Digit meter	MAX.22 mA	$\pm (50\text{ppm} + 0.4\mu\text{A})$	Digit meter:KEITHLEY 2000 Standard resistance:BZ10-100Ω
Measurement	DCA 20mA	Standard source	MAX.33mA	$\pm (100\text{ppm} + 0.2\mu\text{A})$	5520 (FLUKE) or equivalent
	DCV 28V	Standard source	MAX.33V	$\pm (12\text{ppm} + 15\mu\text{V})$	

**Ambient Condition for Calibration**

Ambient temperature: **23°C±1°C** ;  
 Relative humidity: 45 to 75% RH;  
 Preheating: standard instrument should be preheated to specified time;

Put this Instrument in calibration environment for 24 hours, then connect to the power, and set it in non auto-power-off state, and preheat for half an hour.

⚠ **Note**

Power supply for calibrator: during the calibration, it

is recommendable to use 2 1.5V (LR6) batteries.

### Operating Output Calibration

Operating calibration in order of items and calibration points listed in Table 10-2:

Table 10-2

Item No.	Output Range	Calibration Point
1	DCA/20mA	0
		0 FS
		FS

- 1) In power-off state, press the keys (OUTPUT / INPUT) and (power) simultaneously to power on, and release the (OUTPUT / INPUT) key only after the LCD displays all the contents. The Instrument enters into the calibration mode, and the symbols 'CAL 0' appear in the LCD;
- 2) Press the key (OUTPUT / INPUT) to select output function, and the LCD displays 'OUTPUT', 'mA';
- 3) Connect to the Instrument as shown in Figure 10-1;
- 4) Set the digital meter to an appropriate range;

- 5) When the output stabilized, press the key (τ) / (υ) and the key (π) / (θ) to adjust the calibrator to a value in identity with the reading of the digit meter;
- 6) Press the key (100%/START), and the LCD displays 'SAVE', denoting that the calibrated point has been stored;

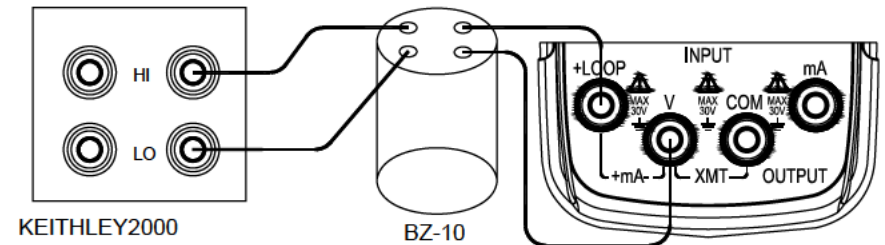

Figure 10-1

- 7) Press the key (STEP/AUTO) and the LCD displays 'CAL 0 FS'. With the output stabilized, repeat the operation of steps 5 and 6;
- 8) Press the key (STEP/AUTO) and the LCD displays 'CAL 0 FS'. With the output stabilized, repeat the operation of steps 5 and 6.

### Operating Input Calibration

Operating calibration in order of items and calibration points in Table 10-3:

Table 10-3

Item No.	Input Range	Calibration Point

1	DCA/20mA	0 : 00.000mA
		FS : 19.000mA
2	DCV/28V	0 : 00.000V
		FS : 19.000V

### Current Measurement Calibration

- 1) In power-off state, press the keys ( OUTPUT / INPUT ) and ( power ) simultaneously to power on, and release the ( OUTPUT / INPUT ) key only after the LCD displays all the contents. The Instrument enters into the calibration mode, and the symbols 'CAL 0' appear in the LCD.
- 2) Press the ( OUTPUT / INPUT ) key to select measurement function , and the LCD displays 'INPUT', 'mA';
- 3) Connect to the Instrument as shown in Figure 10-2;

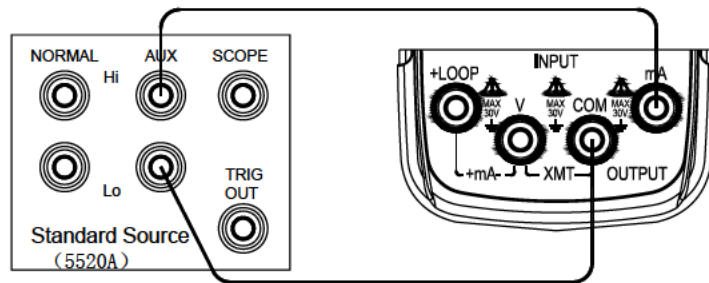

Figure 10-2

- 4) Set the standard source to an appropriate range;

- 5) Set the output of standard source as the value given in Table 10-3 and when the output stabilized , press the ( 100%/START ) key, and the LCD displays 'SAVE' , denoting that the calibrated point has been stored;
- 6) Press the key ( STEP/AUTO ) and the LCD displays 'CAL FS' , and repeat the operation of steps 5.

### Voltage Measurement Calibration

- 1) Press the key ( mA % / V ) to select voltage measurement function , and the LCD displays 'INPUT', 'CAL 0', 'V';
- 2) Connect to the Instrument as shown in Figure 10-3;
- 3) Set the standard source to an appropriate range;
- 4) Set the output of standard source as the value given in Table 10-3 and when the output stabilized , press the key ( 100%/START ) , and the LCD displays 'SAVE' , denoting that the calibrated point has been stored;

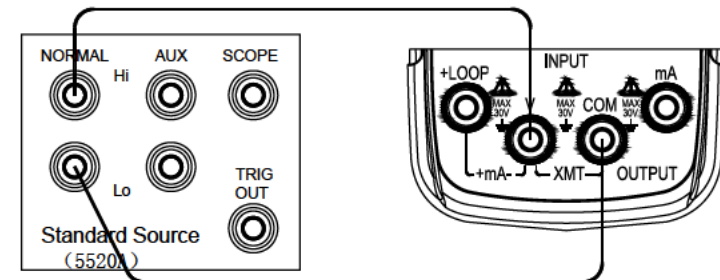

Figure 10-3

- 5) Press the key (STEP/AUTO) and the LCD displays 'CAL FS', and repeat the operation of steps 4.

### ***Section Ten Notice of the Manual***

- The present operation instruction is subject to change without notice;
- The content of the operation instruction is regarded as correct. Whenever any user finds its mistakes, omission, etc., he or she is requested to contact the manufacturer;
- The present manufacturer is not liable for any accident and hazard arising from the customer misuse or inadvertent operation;
- The functions described in this operation instruction should not be used as grounds to apply this product to a particular purpose.